

DIMENSIONI D'INGOMBRO - OVERALL DIMENSIONS

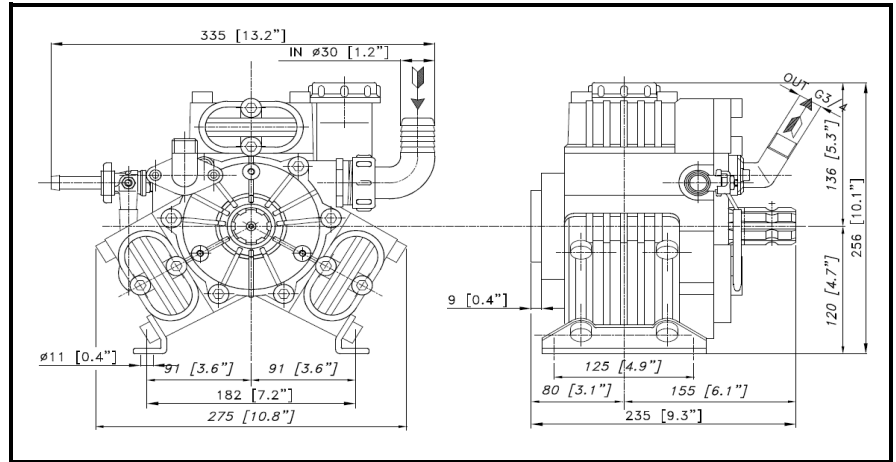

ALBERO POMPA - PUMP SHAFT

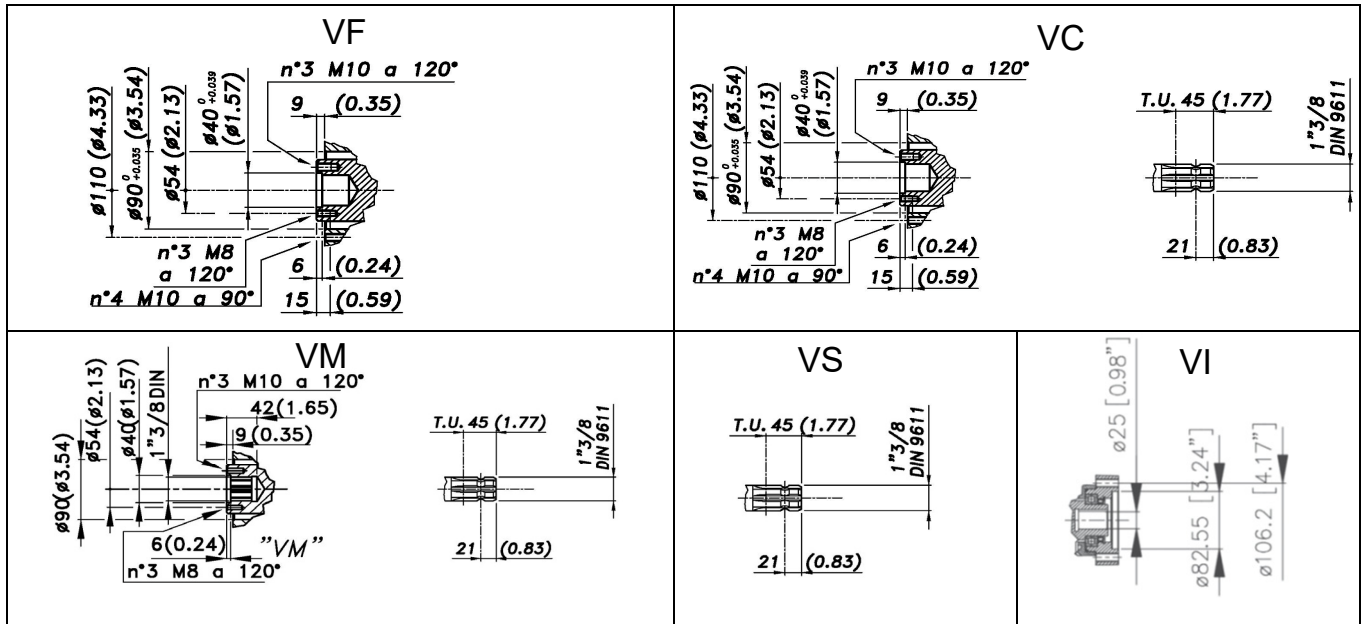

COPPIA DI SERRAGGIO - TORQUE CHART

CODICE - CODE	Q.TY	POS	N-m	Lbr.ft
23.0015.51.2	3	4	12	9
86.2168.00.2	2	40	10	7
86.2216.00.2	6	39	10	7
86.2730.00.2	2	28	10	7
86.3185.00.2	4	18	22	16
86.3300.00.2	6	48	44	33
86.3560.00.2	8	46	44	33
86.3562.00.2	4	32	44	33
23.0043.98.3	3	4	12	9

Tolleranza di serraggio: 0/-10%
Tolerance on torque value:

INFORMAZIONI UTILI
USEFUL INFORMATION

LUBRIFICANTE - LUBRICANT:				
OLIO MOTORE O SEMIDRAULICO SAE 30 MOTOR OIL OR SEMI-HYDRAULIC OIL SAE 30				
PRESSIONE ACCUMULATORE ACCUMULATOR PRESSURE				
PRESSIONE DI LAVORO - OPERATING PRESSURE	2 ÷ 5	5 ÷ 10	10 ÷ 20	20 ÷ 50
ACCUMULATORE ACCUMULATOR	/	/	/	/

KIT MEMBRANE - DIAPHRAGMS KIT

KIT	BUNA - N		PRE-SET DESMOPAN		PRE-SET DURAMAX		VITON						PENTAX		
	23.9828.97.3	23.9873.97.3	23.9873.97.3DS	23.9826.97.3	23.9826.97.3	23.9875.97.3	1	44	45	49	50	36	37	1	45
POSIZIONE ESPLOSO POSITION NUMBER	1	45	1	45	1	45	1	44	45	49	50	36	37	1	45
QUANTITA' NEL KIT QUANTITIES INCLUDED	3	6	3	6	3	6	3	1	6	6	6	1	1	3	6

KIT POMPA/KIT VALVOLE - PUMP KIT/VALVES KIT

KIT	KIT POMPA VM PUMP KIT VM							KIT VALVOLE VALVE KIT					
	23.9880.97.3	23.9829.97.3	35	19	44	45	49	50	36	37	2	50	49
POSIZIONE ESPLOSO POSITION NUMBER	1	1	1	6	6	6	1	1	6	6	6		
QUANTITA' NEL KIT QUANTITIES INCLUDED	1	1	1	6	6	6	1	1	6	6	6		

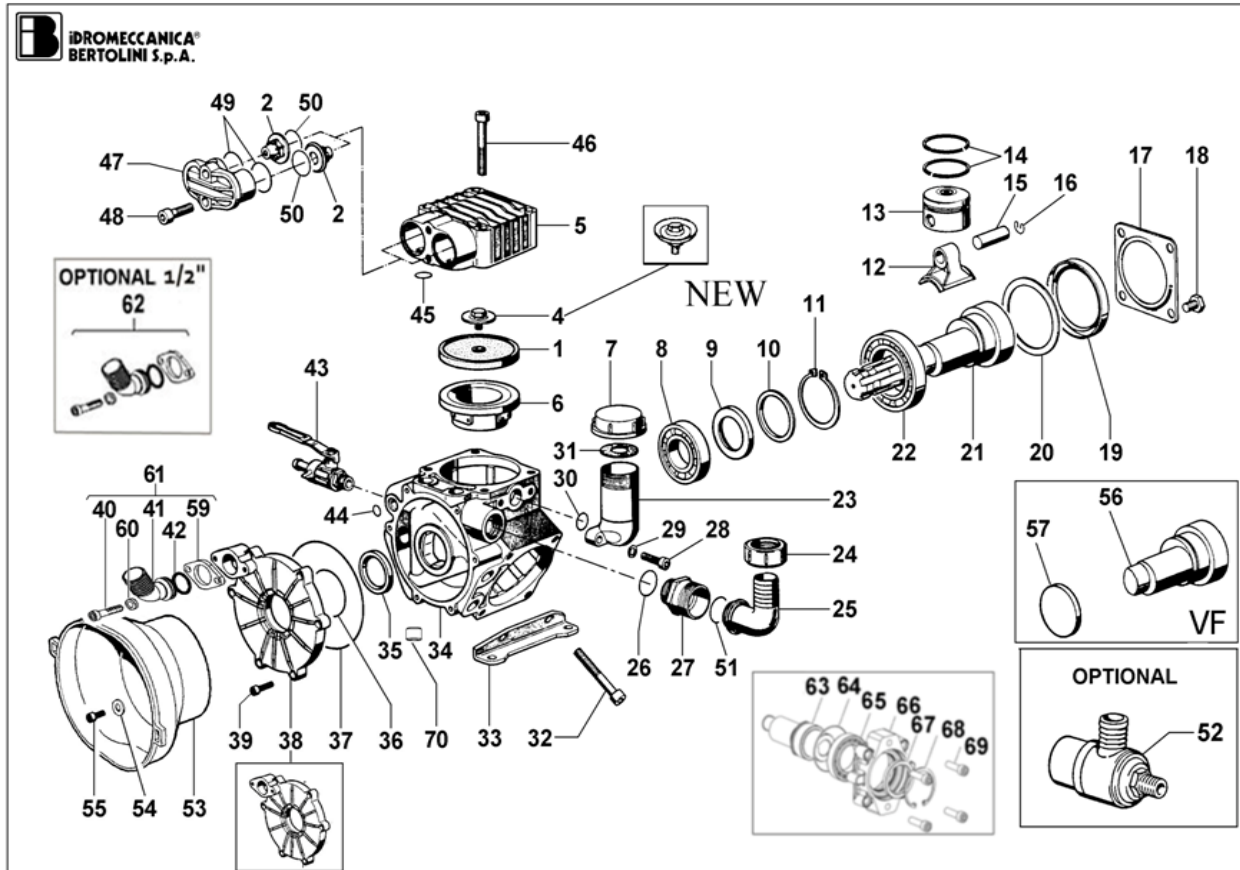

POS.	CODICE PART NO. REF.	DENOMINAZIONE - DESCRIPTION - DESCRIPTION	Q.TY	POS.	CODICE PART NO. REF.	DENOMINAZIONE - DESCRIPTION - DESCRIPTION	Q.TY
1	23.0011.31.2	PISTON DIAPHRAGM BUNA-N	3	34	80.2134.50.2	CRANKCASE till the 04/2016	1
1	23.0011.33.2	VITON PISTON DIAPHRAGM	3	34	23.0201.09.2	CRANKCASE from the 05/2016	1
1	23.0011.36.2	HPS PISTON DIAPHRAGM	3	35	80.2134.50.2	OIL SEAL DIA.35x47x7	1
1	23.0012.00.2	PRE-SET DESMOPAN PISTON DIAPHRAGM	3	36	80.3209.80.2	O-RING 2,62x50,47	1
1	23.0012.00.2DS	PRE-SET DURAMAX PISTON DIAPHRAGM	3	36	80.3209.85.2	O-RING 2,62x50,47 (KIT VITON)	1
2	23.9805.97.3	VALVE ASSY	6	37	80.3210.68.2	O-RING 2,62x120,32	1
4	23.0043.98.3	KIT DIAPHRAGM WASHER/SCREW AISI 316	3	37	80.3210.69.2	O-RING 2,62x120,32 (KIT VITON)	1
4	23.0015.51.3	DIAPHRAGM SCREW (before 12/98)	3	38	23.0046.09.2	CRANKCASE COVER till the 04/2016	1
4	23.0009.32.2	DIAPHRAGM WASHER (before 12/98)	3	38	23.0006.09.2	CRANKCASE COVER till the 06/1999	1
5	23.0002.09.2	HEAD	3	38	23.0212.09.2	CRANKCASE COVER from the 05/2016	1
6	23.0020.01.2	PISTON SLEEVE D.55 (PA 530)	3	39	86.2216.00.2	SCREW M6x25 UNI5931	6
6	23.0066.01.2	PISTON SLEEVE D.55 (PA 530/1000)	3	40	86.2108.00.2	SCREW M6x16 UNI5931	2
7	85.2750.00.2	OIL FILLER CAP (before 08/2020)	1	41	31.1516.09.2	DIRECTIONAL FITTING G.3/4	1
7	85.2750.00.2A	OIL FILLER CAP (from 09/2020)	1	42	80.3218.00.2	O-RING 3,0x22	1
8	81.2846.00.2	BEARING DIA.35x72x17	1	43	84.5544.10.2	LEFT TAP G.3/8-G.1/2	1
9	23.0019.76.2	RING	1	44	80.3176.00.2	O-RING 2,62x11,91 till the 04/2016	1
10	26.0047.76.2	RING	1	44	80.3176.50.2	O-RING 2,62x11,91 (KIT VITON) till the 04/2016	1
11	80.1377.00.2	RING DIA.55 "VF"-VC"-VM"	1	44	80.3189.00.2	O-RING 2,62x18,72 from the 05/2016	1
12	23.0005.09.2	LIGHT ALLOY CONROD	3	44	80.3189.50.2	O-RING 2,62x18,72 (KIT VITON) from the 05/2016	1
12	23.0045.11.2	BRONZE CONROD	3	45	80.3189.00.2	O-RING 2,62x18,72	6
13	23.0007.09.2	PISTON D.55	3	45	80.3189.50.2	O-RING 2,62x18,72 (KIT VITON)	6
14	81.8504.50.2	PISTON RING	6	46	86.3560.00.2	SCREW M10X65 UNI 5931	8
15	85.2006.70.2	PISTON PIN DIA.15	3	47	23.0003.09.2	VALVE COVER	3
16	80.0021.00.2	RING DIA.15	6	48	86.3300.00.2	SCREW M10x30 UNI5931	6
17	17.0013.61.2	COVER	1	49	80.3219.20.2	O-RING 3,0x35	6
18	86.3187.10.2	SCREW M10x16 UNI5931	4	49	80.3219.50.2	O-RING 3,0x35 (KIT VITON)	6
19	80.2264.10.2	OIL SEAL DIA.68x90x10 "VF"-VC"-VM"	1	50	80.3207.00.2	O-RING 2,62x29,82	6
19	80.2156.00.2	CAP "VS"	1	50	80.3207.50.2	O-RING 2,62x29,82 (KIT VITON)	6
20	17.0024.76.2	SPACER	1	51	80.3219.00.2	O-RING 3,0x25	1
21	22.0310.26.2	CRANKSHAFT"VC"(PA 530)	1	52	24.3040.97.3	SAFETY VALVE 40bar (OPTIONAL)	1
21	23.0065.26.2	CRANKSHAFT"VC"(PA 530/1000)	1	53	31.1467.32.2	SAFETY CONE (OPTIONAL)	1
21	23.0024.26.2	CRANKSHAFT "VM" (1"3/8 M-F)	1	54	84.3618.00.2	WASHER DIA.6,4x18x1,5 (OPTIONAL)	3
21	23.0036.26.2	CRANKSHAFT "VS" (1"3/8 M)	1	55	86.2086.00.2	SCREW M6x14 UNI5931 (OPTIONAL)	3
22	81.2972.00.2	BEARING DIA.55x90x18	1	56	23.0028.26.2	CRANKSHAFT"VF"(SEE OVERALL DIMENSIONS)	1
23	23.0008.32.2	OIL FILLER	1	57	80.2099.50.2	COVER "VF"	1
24	82.0067.50.2	WING NUT G.1"1/4	1	59	31.1517.61.2	FLANGE LOCK FITTING	1
25	84.0560.00.2	90° ELBOW CONNECTOR DIA.30-1,18"	1	60	84.3585.00.2	WASHER D.6	2
25	84.0565.00.2	90° ELBOW CONNECTOR DIA.32-1,25" (OPT.)	1	61	31.8917.97.3	FITTING KIT G.3/4"	1
26	80.3207.00.2	O-RING 2,62x29,82	1	62	31.8916.97.3	FITTING KIT G. 1/2" (OPTIONAL)	1
27	83.5089.00.2	NIPPLES G.1"-G.1"1/4	1	63	22.0328.26.2	ALBERO "VI"	1
28	86.2730.00.2	SCREW M8x30 UNI5931	2	64	80.3210.67.2	O-RING 2,62X88,57	1
29	84.3685.00.2	WASHER DIA.8,4x15x1,5	2	65	81.2914.00.2	BEARING 40X90X23	1
30	80.3180.00.2	O-RING 2,62x15,08	1	66	22.0333.09.2	FLANGE	1
31	82.4120.00.2	GASKET DIA.45x19x1,5 (before 08/2020)	1	67	80.2188.10.2	OIL SEAL 40X62X7	1
31	23.0097.31.2	OIL FILLER DIAPHRAGM (from 09/2020)	1	68	80.1400.00.2	RING D.62	1
32	86.3562.00.2	SCREW M10X70 UNI 5931	4	69	86.3347.00.2	SCREW M10X35 UNI5931	4
33	23.0018.61.2	MOUNTING BRACKETS	2	70	85.2541.00.2	PLUG DIN 906 1/4GAS [Loxael 55-14]	1